

WATCH GUARD
440 SERIES FLOAT VALVES
INSTALLATION INSTRUCTIONS
MODELS: 440-22T, 440-22TX, 440-23T, 440-23BT, 440-24

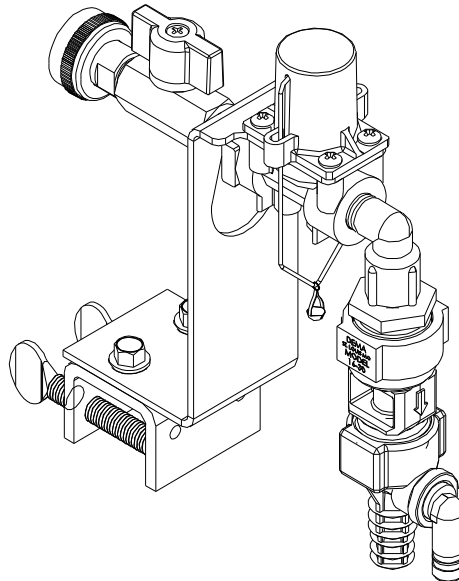

Overview

The Watch Guard 440 Series of float valves fills and maintains fluids in reservoirs. The units are equipped with proportioners and integral backflow preventers to inject chemicals into the reservoir at selected dilution rates.

The Watch Guard 440 Series includes brackets for secure attachment and shut-off ball valves.

Warnings



ALL ELECTRICAL POWER MUST BE TURNED OFF TO THE DISPENSER AND TO THE APPLIED MACHINE.



All installations must conform to local plumbing codes and use approved backflow prevention devices. A pressure indicating tee is to be installed with existing faucets according to local plumbing codes in the state of Wisconsin and any other state that requires the use of a pressure indicating tee.



ALWAYS WEAR PROTECTIVE CLOTHING AND EYEWEAR WHEN WORKING WITH CHEMICAL PRODUCTS.

Specifications

Packing List

- A. Valve Assembly and Brackets
- B. Proportioner with Backflow Preventer (Excluding 440-22 Models)
- C. 8' Long Vinyl Supply Tubing & Foot Valve Assembly
- D. Float and Chain
- E. Ceramic Weight
- F. ½" ID X 3' Long Vinyl Discharge Tubing w/Priming Insert
- G. Metering Tip Kit 61-9K-FV or 100-15K-FV

Operational Requirements

- Pressure: 15-150 psi (1.0-10.3 bar)
- Temperature: 33-120°F (0.6-49.0°C)

Parts List

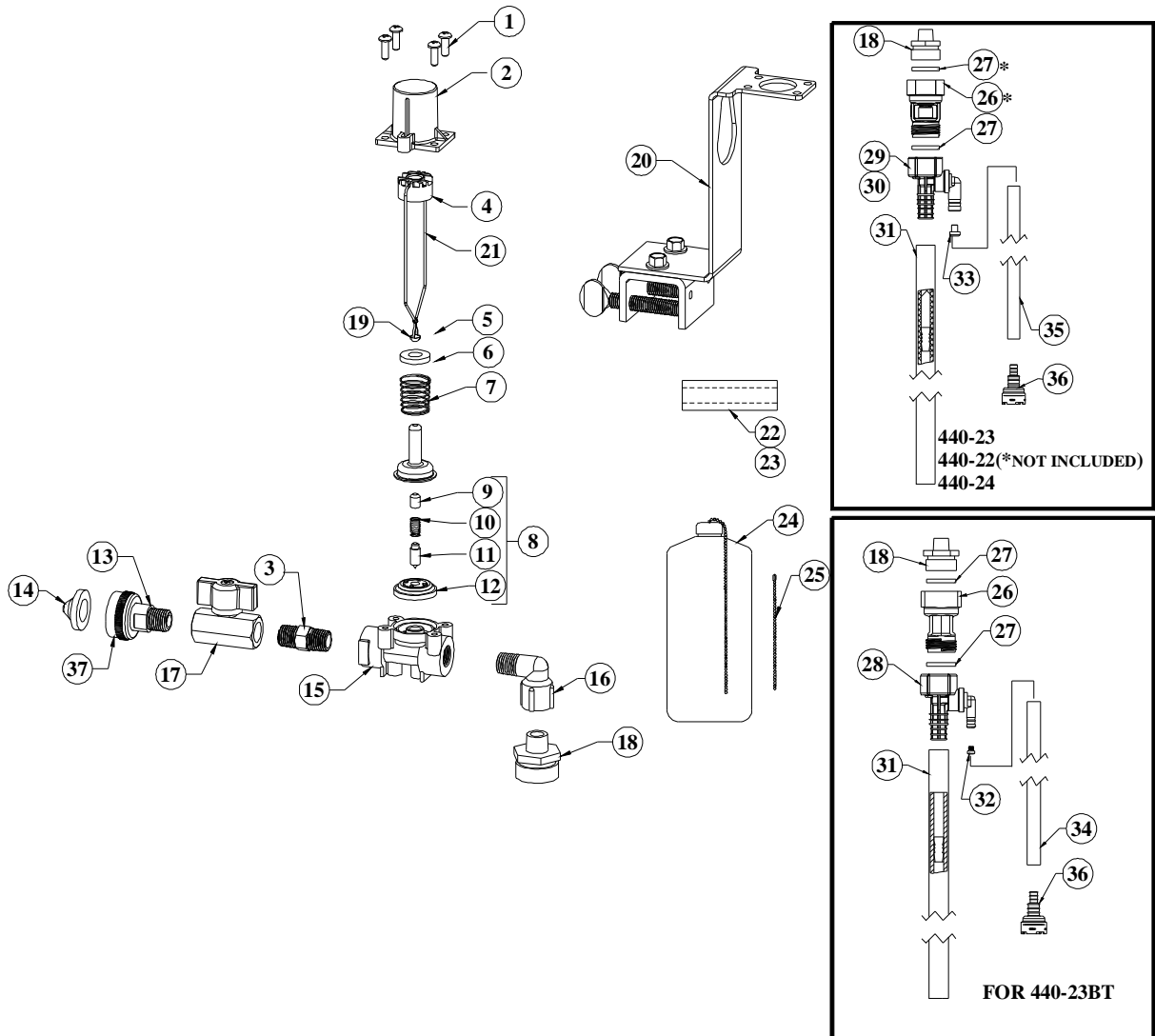

NO.	PART NO.	DESCRIPTION
1	44-116-1	Screws
2	35-44	Magnet Housing
3		¼" Hex Nipple
4	35-43	Magnet Holder
5	63-35	Magnet
6	35-33	Spring
7	41-7-25	Enclosing Tube
8	63-87	Valve Repair Kit
9	63-37	Spacer
10	41-1-8	Spring
11	63-38	Plunger
12	41-15-10	Diaphragm
13	61-120	Inlet Hose Adapter
14	100-38	Inlet Washer Screen
15	35-36	Valve Body
16	50-63	Street Elbow, Polypropylene
17	16-11	Ball Valve
18	61-122-2	Adapter (MGHT x ¼" MNPT)
19	35-12	Float Hanger Clip

NO.	PART NO.	DESCRIPTION
20		Mounting Bracket Assembly
21	35-42	Float Hanger Wire
22	61-107-5	Ceramic Weight (For 3/8" Tube)
23	61-107-4	Ceramic Weight (For 1/4" Tube)
24	35-18	Float Assembly
25	34-17	16" Chain w/Connector (Optional)
26	16-30	Action Gap Backflow Preventer
27	150-6	Rubber Washer
28	61-22-3	4 GPM (1/4" Barb) White Proportioner
29	61-22-2	4 GPM (3/8" Barb) White Proportioner
30	61-97	2.5 GPM (3/8" Barb) Blue Proportioner (440-24 Models)
31	16-3-24-1	2' Discharge Tubing & Primer
32	100-15	Metering Tip (Specify Color)
33	61-9	Metering Tip (Specify Color)
34	100-12	8' Plastic Tubing (7/32" ID)
35	100-12L	8' Plastic Tubing (3/8" ID)
*36	100-16V	Foot Valve
37		Swivel

Installation

A. Valve Bracket and Proportioner Assembly:

Attach bracket to tank as shown in figure #1 or # 2. Connect a garden hose to the valve assembly or mount the valve assembly directly to a ¼ NPT pipe line by removing the inlet garden hose adapter. If using a ¼ NPT connection, apply pipe dope or 2-3 wraps of Teflon tape, hand tighten. Then turn with a wrench until snug. **DO NOT OVER TIGHTEN.**

Plastic discharge tubing is supplied and must be used. Discharge tubing should be shortened to avoid kinks. 12" tube length is required for proper operation. The discharge tubing outlet should be below the bottom of the float.

B. Float and Chain:

Run chain through the clip on the pull wire until the top of the float is about 1 or 2 inches above the desired maximum water level (with pull wire in "up" position). Snap the bead into the clip to hold the chain in place. Excess chain may be cut off if so desired. (See Figure #1).

C. Chemical Supply:

Place the chemical container in a convenient location not more than 6 feet below the valve, (greater lifts will reduce injection capacities). Slip the ceramic weight over the chemical intake tubing. Insert the end with the foot valve of the 8 foot vinyl tubing into the chemical container. Cut the tubing to any convenient length that will allow it to extend from the bottom of the chemical container to the proportioner inlet barb (See Figure #1). Thread desired metering tip into the barb end, then slide tubing over the metering tip and barb.

CHEMICAL INJECTION ADJUSTMENTS:

WARNING: USE CARE WHEN HANDLING HAZARDOUS CHEMICALS.

Metering tips are used to control chemical dilution rates. Tables 1, 2, & 3 show the dilution ratios for various chemical viscosities. For highly viscous products, the induction rate can be increased by substituting 1/2" ID inlet tubing. (Leave a short piece of 3/8" ID tubing on proportioner and foot valve barbs as bushings.)

1 cps (Centipoise) is equal to the viscosity of water
75 cps is approximately equal to the viscosity of 10 weight motor oil
200 cps is approximately equal to the viscosity of most dishwashing detergents

61-9K (3/8" BARB)		
DEMA TIP COLOR	HYDROMINDER EQUIVALENT TIP	ORIFICE SIZE
NO TIP	NO TIP	N/A
ORANGE	GRY,BLK	.0770
WHITE	BEIGE	.0685
BROWN	N/A	.0605
BLUE	RED	.0550
RED	RED	.0490
GREY	WHITE	.0430
BLACK	BLUE	.0375
TURQUOISE	TAN	.0345
PINK	GREEN	.0255
GREEN	ORANGE/BROWN	.0225
YELLOW	YELLOW/PURPLE	.0175
PURPLE	PURPLE	.0125
CLEAR	PINK	.0090
100-15KU ULTRA-LEAN (1/4" BARB)		
LIME GREEN	N/A	.0085
BURGUNDY	N/A	.0076
AMBER	N/A	.0065
COPPER	N/A	.0058

100-15K (1/4" BARB)		
DEMA TIP COLOR	HYDROMINDER EQUIVALENT TIP	ORIFICE SIZE
GREY	GRY,BLK,BEIGE	.0600
PURPLE	RED	.0540
LIGHT ORANGE	WHITE	.0480
BLACK	BLUE	.0375
YELLOW	TAN	.0329
BLUE	GREEN	.0267
GREEN	ORANGE	.0240
WHITE	BROWN	.0223
RED	YELLOW	.0210
BROWN	N/A	.0183
LIGHT BLUE	N/A	.0167
PINK	PURPLE	.0152
TURQUOISE	PINK	.0114
ORANGE	N/A	.0109
TAN	N/A	.0098

LIQUID PROPORTIONING LEVEL CONTROL

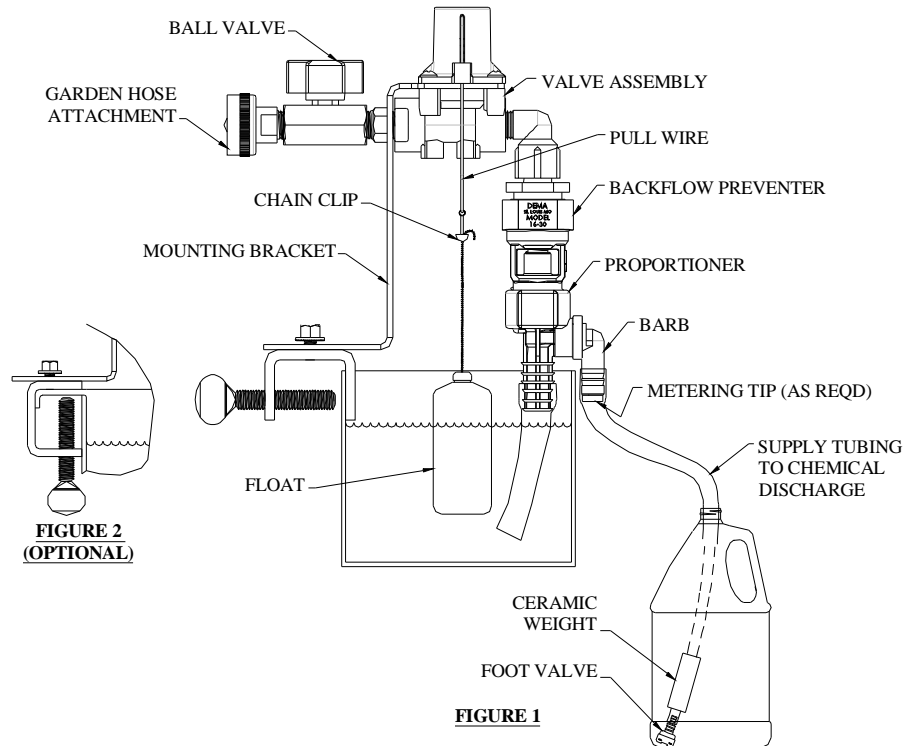

Operation

At least 15 PSI pressure must be available to induct chemical. Turn on water to the unit. Open the ball valve. As the tank fills, chemical concentrate will be drawn up through the plastic tubing and will mix with the incoming water. The valve will close when water reaches approximately 1-2 inches below the top of the float. The float valve will operate again when the water level drops approximately 4 inches.

Troubleshooting

CAUTION: TURN OFF WATER SUPPLY BEFORE SERVICING.

A. Proportioner fails to draw chemical:

1. Proportioner outlet tubing cut too short or not attached. Pinch outlet tube to create back pressure, which will cause unit to prime. The foot valve will keep the inlet tube primed after initial use.
2. Insufficient water supply pressure. 15 psi is the minimum required water pressure.
3. Chemical inlet may be drawing air.

B. Proportioner stops drawing chemical:

1. Inspect foot valve for dried chemical or dirt. Soak in hot water to clean.
2. Proportioner metering tip clogged with dried chemical. Remove tip and soak in hot water. If there is no suction, remove proportioner and soak in hot water to clear interior passages.
3. If there is a buildup of calcium carbonate (lime) inside the proportioner, soak component in a vinegar or D-Limonene solution.
4. Chemical inlet may be drawing air.

C. Proportioner continues drawing chemical after water valve closes:

1. Chemical supply is higher than bottom of discharge tube creating a natural siphon. Lower the supply container.

D. Valve malfunction:

1. Check that the wire moves freely up & down and that a “click” can be heard when the wire is pulled and released, indicating that the magnet is activating the plunger properly. To inspect internal parts, remove magnet housing and carefully pull off the enclosing tube so as not to drop the plunger, kick-off spring and spacer. Check for dirt or damage impeding plunger and kick-off spring movement. Inspect the diaphragm, making sure two small pin holes (bleed holes) in the diaphragm are clear to allow the valve to close.
2. Valve will not operate if pressure exceeds 150 psi.

CAUTION: When servicing unit, be sure that replacement parts have been installed according to drawing.

- Note: All induction rates are based on a water pressure of 40 psi.

Table 1
440-23BT, 440-23BT-KR (White proportioner with 1/4" hose barb)

Metering Tip Color	Injection Rates For Viscosities Shown					
	1 cps		75 cps		200 cps	
	Oz/Gal	Ratio	Oz/Gal	Ratio	Oz/Gal	Ratio
Tan	0.33	387-1	0.26	500-1	0.12	1090-1
Orange	0.42	307-1	0.32	430-1	0.17	735-1
Turquoise	0.51	256-1	0.34	382-1	0.19	676-1
Pink	0.78	165-1	0.56	230-1	0.3	422-1
Clear	0.87	147-1	0.67	192-1	0.33	391-1
Brown	0.99	128-1	0.74	174-1	0.37	345-1
Red	1.37	93-1	0.91	141-1	0.44	289-1
White	1.52	84-1	1.04	128-1	0.48	264-1
Green	1.72	74-1	1.22	105-1	0.52	244-1
Blue	2.13	60-1	1.27	101-1	0.54	239-1
Yellow	3.05	42-1	1.71	75-1	0.56	229-1
Black	4.50	28-1	1.96	64-1	0.57	224-1
Purple	7.75	17-1	2.4	53-1	0.59	217-1
Gray	9.86	13-1	2.54	50-1	0.63	204-1
No Tip	19.63	7-1	3.16	40-1	0.67	190-1

Table 2
440-22T, 440-22T-KR, 440-23T, 440-23T-KR (White proportioner with 3/8" hose barb)

Metering Tip Color	Injection Rates For Viscosities Shown					
	1 cps		75 cps		200 cps	
	Oz/Gal	Ratio	Oz/Gal	Ratio	Oz/Gal	Ratio
Clear	0.30	430-1	0.22	592-1	0.13	864-1
Purple	0.48	265-1	0.32	406-1	0.24	524-1
Yellow	1.28	100-1	0.82	157-1	0.6	212-1
Green	1.67	77-1	1.29	99-1	1	128-1
Pink	2.36	54-1	1.65	77-1	1.25	103-1
Turquoise	3.76	34-1	2.55	50-1	1.85	69-1
Black	4.47	29-1	3.03	42-1	2.12	60-1
Gray	5.53	23-1	3.67	35-1	2.58	50-1
Red	7.00	18-1	4.79	27-1	2.79	46-1
Blue	8.78	15-1	5.39	24-1	3.06	42-1
Brown	10.95	12-1	6.49	20-1	3.35	38-1
White	14.19	9-1	7.08	18-1	3.46	37-1
Orange	17.58	7-1	7.91	16-1	3.71	35-1
Light Blue*	21.75	6-1	8.66	15-1	3.9	33-1
Tan*	27.98	5-1	9.15	14-1	4.11	32-1
No Tip	33.15	4-1	10.54	12-1	4.52	28-1

Table 3
440-24, 440-24-KR (Blue proportioner with 3/8" hose barb)

Metering Tip Color	Injection Rates For Viscosities Shown					
	1 cps		75 cps		200 cps	
	Oz/Gal	Ratio	Oz/Gal	Ratio	Oz/Gal	Ratio
Clear	0.66	195-1	.027	470-1	.14	903-1
Purple	1.01	128-1	.041	315-1	.33	393-1
Yellow	1.53	83-1	1.03	128-1	.86	148-1
Green	2.52	51-1	1.64	78-1	1.44	89-1
Pink	3.53	36-1	2.04	64-1	2.09	64-1
Turquoise	5.73	22-1	3.24	40-1	2.92	44-1
Black	6.72	19-1	3.88	32-1	3.34	38-1
Gray	8.95	14-1	4.98	26-1	4.04	32-1
Red	12.34	10-1	6.22	21-1	4.67	27-1
Blue	14.00	9-1	7.28	18-1	4.99	26-1
Brown	18.68	7-1	9.02	14-1	5.35	24-1
White	24.45	5-1	10.35	12-1	5.53	23-1
Orange	30.97	4-1	11.86	11-1	5.88	22-1
Light Blue*	38.26	3-1	13.31	10-1	6.22	21-1
Tan*	53.96	2.5-1	15.21	8-1	6.49	20-1
No Tip	66.07	2-1	18.61	7-1	7.07	18-1

* These tips are not included in the standard tip pack.

Warranty

NO MERCHANDISE MAY BE RETURNED FOR CREDIT WITHOUT DEMA'S WRITTEN PERMISSION. RETURN MERCHANDISE AUTHORIZATION NUMBER REQUIRED IN ADVANCE OF RETURN.

WARRANTY: DEMA products are warranted against defective material and workmanship under normal use and service for one year from the date of manufacture. This limited warranty does not apply to any products, which have a normal life shorter than one year or failure and damage caused by chemicals, corrosion, improper voltage supply, physical abuse, or misapplication. Rubber and synthetic rubber parts such as "o"- rings, diaphragms, squeeze tubing and gaskets are considered expendable and are not covered under warranty. This warranty is extended only to the original buyer of DEMA products. If products are altered or repaired without prior approval of DEMA, this warranty will be void.

Defective units or parts should be returned to the factory with transportation prepaid. If inspection shows them to be defective, they will be repaired or replaced without charge, F.O.B. factory. DEMA assumes no liability for damages. Return merchandise authorization number, to return units for repair or replacement, must be granted in advance of return.